

# 4<sup>TH</sup> EDITION Bike Fit

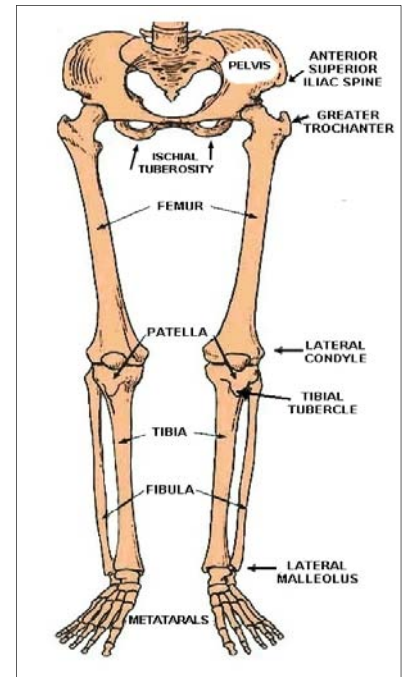

Arnie Baker, MD

<http://arniebakercycling.com>



*4<sup>TH</sup> EDITION*

# **Bike Fit**

**Arnie Baker, MD**



<http://arniebakercycling.com>

## Copyright

The materials available in *Arnie Baker Cycling* and/or *Argo Publishing* products (collectively subsequently referred to as *Arnie Baker Cycling*), both in print and online, are the property of *Arnie Baker* and are protected under United States and international copyright and other laws and conventions.

*Arnie Baker Cycling* grants to you, the customer, a nontransferable, nonexclusive right and revocable license to use this material according to the terms and conditions set forth in this Agreement.

Except as expressly granted by this Agreement, you acquire no right, title, or license to the contents of *Arnie Baker Cycling* products or its website.

Some material is derived from previously published works of Arnie Baker, or includes material previously written and published for or derived from works of the United States Cycling Federation or commercial/trade books.

The information contained herein is for the personal use of the reader, and may not be incorporated into any commercial programs, other books, databases or any other kind of software without the written consent of the author.

Making copies *Arnie Baker Cycling* publications, or any portion, for any purposes other than your own is a violation of United States copyright laws.

The occasional use of trademarked names is for editorial purposes only. There is no intention to infringe upon trademarks. No endorsement or denigration of any product is implied.

Copyright © 1988-2009, by Arnie Baker.

Arnie Baker Cycling <http://arniebakercycling.com/>

Argo Publishing 1820 Washington Place San Diego, CA 92103

## Limitations of Use

All rights reserved.

The contents of *Arnie Baker Cycling* publications may be accessed, viewed or otherwise used only by a registered customer. Customers are permitted to view, browse, download, and/or print for their own personal purposes only. These uses are restricted to noncommercial purposes; all copyright and any other notices must be maintained on all copies.

Any and all materials may have electronic expiration dates. Use of materials beyond their expiration date is prohibited. Using “work-arounds” or programs to defeat electronically set expiration dates is prohibited.

Except as provided by law or by this agreement, the contents of *Arnie Baker Cycling* publications or its website may not be further stored, reproduced, distributed, transmitted, modified, adapted, performed, displayed (including adaptations/displays such as by “framing”), published, printed, or sold in whole or in part without prior written permission from *Arnie Baker Cycling*.

*Arnie Baker Cycling* publications may not be duplicated in any way without the expressed written consent of the author, except in the form of brief excerpts or quotations for the purposes of review.

Sharing a password with a non-customer or otherwise making the contents of *Arnie Baker Cycling* publications available to third parties is strictly prohibited.

Unauthorized use may subject the user to applicable civil or criminal penalties.

## Changes in Terms and Conditions

*Arnie Baker Cycling* reserves the right at its discretion to change, modify, add or remove the Terms and Conditions of this Agreement at any time and post the changes on its website.

Continued use of the website following the posting and such notification of any change to these Terms and Conditions will constitute acceptance by you of the Terms and Conditions as modified.

*Arnie Baker Cycling* reserves the right to change, modify, suspend or discontinue any or all parts of the website or the material available at any time and reserves the right to restrict access to parts or all without notice or liability.

## Disclaimer

The author makes no warranty of any kind, expressed or implied, with regard to the information contained in *Arnie Baker Cycling* publications or its website.

*Arnie Baker Cycling* does not guarantee the accuracy, completeness, currentness, noninfringement, merchantability, or fitness for a particular purpose of information available from its publications or website.

The author shall not be liable in the event of incidental or consequential damages in connection with, or arising out of, the furnishing, performance, or use of information, associated instructions, programs, and/or claims of results or productivity gains.

Generalizations or applicability of information contained in this book may not apply to any specific individual.

The contents of *Arnie Baker Cycling* publications or its website should not be substituted for the advice of a personal physician.

All readers are cautioned to obtain medical consultation in the event of any medical problems. All readers are cautioned to consider obtaining medical consultation before entering into any athletic training program.

*Arnie Baker Cycling* will not be liable for any loss or injury caused by information obtained through its publications or its website.

In no event will *Arnie Baker Cycling* be liable for any decision made or action taken in reliance on such information.

*Arnie Baker Cycling* will not be liable for any damages arising out of any legal claim in any way connected with the information provided in its publications or on its website.

## Cataloging in Publication Data

Baker, Arnie, 1953-

Bike Fit/

by Arnie Baker.

—4.5 ed.

Bibliography. Includes index.

1. Bicycling

2. Sports Training

3. Bicycle Fit

I. Title

2010

10 9 8 7 6 5 4

## **Arnie Baker, MD**

---

Dr. Arnie Baker has been coaching since 1987. A professional, licensed USCF coach, he has coached racers to several Olympic Games, more than 100 U.S. National Championships, and 35 U.S. records. He is the National Cycling Coach for Team in Training. This endurance-training program of more than 800 coaches and 30,000 participants raises more than \$80,000,000 each year for the Leukemia & Lymphoma Society.

Arnie has a Category 1 USCF racing license. He has held eight U.S. 40-K time-trial records, has won multiple national championships, and has won more than 200 races. An all-round racer, he was the first to medal in every championship event in his district in a single year.

Dr. Baker is a licensed physician in San Diego, California. He obtained his M.D. as well as a master's degree in surgery from McGill University, Montreal. He is a board-certified family practitioner. Before retiring to ride, coach, and write, he devoted approximately half of his medical practice to bicyclists. He has served on the fitness board of *Bicycling* magazine as a bicycling-physician consultant. He has been a medical consultant to USA Cycling and the International Olympic Committee.

Arnie has authored or co-authored 18 books and more than 1,000 articles on bicycling and bicycling-related subjects.

### **Also by Arnie Baker, MD:**

- Altitude Climbing Endurance (ACE) Training for Cyclists
- Bicycling Medicine—Cycling Nutrition, Physiology and Injury Prevention, and Treatment
- High-Intensity Training (HIT) for Cyclists
- Nutrition for Sports
- Psychling Psychology: Mind Training for Cyclists
- Skills Training for Cyclists
- Smart Coaching
- Smart Cycling—Successful Training & Racing
- Strategy & Tactics for Cyclists
- The Essential Cyclist
- The Wiki Defense: How the French Lab (LNDD) & US Anti-Doping Agency Botched Floyd's Test

# Thank You for Your Purchase

---

If you bought this eBook from [arniebakercycling.com/](http://arniebakercycling.com/), [roadbikerider.com/](http://roadbikerider.com/), or other authorized website (listed at [tinyurl.com/cvpv7a](http://tinyurl.com/cvpv7a)), thank you.

I hope you will find this eBook worthwhile.

If you have received this eBook without proper payment (perhaps a friend e-mailed it to you), please keep in mind that this book is not meant for free distribution.

By all means, use this book to your benefit. However, please make a payment (via credit card or PayPal) for \$19.95 at [http://arniebakercycling.com/pay/pay\\_via\\_paypal.htm](http://arniebakercycling.com/pay/pay_via_paypal.htm) or send a check in that amount to Arnie Baker Cycling, 1820 Washington Place, San Diego, CA 92103 USA.

Thank you.

## Acknowledgments

---

I thank Barbara Baker and Gero McGuffin for proofing and other valuable suggestions.

I thank Lon Haldeman, Maury Hull, Andy Pruitt, and Paul Swift for sharing their bike fitting concepts. I thank Gale Bernhardt for bringing the myth of women and long legs to my attention. I would like to give a little credit and mention to CONI.<sup>1</sup>

I thank Gero McGuffin, Jimena Florit, Chuck Gilbert, Tom Hendricks, Janel Holcomb, and Butch Richardson for serving as models.

---

<sup>1</sup> Here it is: A little mention of CONI. *Cycling* was published in 1972 by CONI, Comitato Olimpico Nazionale Italiano (the Italian Olympic Committee). It was the first authoritative book on cycling I read, the then bible of bicycling. The book contains a wealth of information. It is also wordy and often obscure, at times more difficult to read in its English translation than any medical text I have ever studied. Consider CONI on bike fit changes to pedal position:

My style: "Make changes gradually, allow the body time to adapt."

The CONI wisdom: "Any changes in respect of a satisfactory position are not adopted race by race, that is, according to the diversity of the race itself, since the position, once established, should not be modified. In fact, to change the position of the foot is equivalent to modifying the aptitudes which the muscles and nerves of the lower limbs have assumed with time and work, until such aptitudes have become veritable habits, so that if such habits are suddenly changed, the cyclists will be subject to pain in the legs and cramps."

# Disclosure

---

Dr. Baker receives or has received sponsorship or products from:

Adams Avenue Bicycles, Bell Sports, Bike Friday, Bike USA, Bill Holland Bicycles, Boone Technologies, Cannondale, Chris King, CompuTrainer, Continental, CycleOps, LeMond Fitness, Lew Composites, Mavic USA, Pantour, Pasadena Bicycle Manufacturing, Polar Electro Oy, PowerFoods, PR Bar, Ralph Ray Engineering, Scott USA, Sidi, Specialized, Speedplay, Tailwings, Trek Bicycle Superstores San Diego, Tune (Power-Tap), VeloMax, Vision Tech, Vredestein, XLM, Xtrem, and Zipp.

Dr. Baker has been a paid consultant for:

Colorado Altitude Training, Kirkwood Mountain Resort, PacTour, The International Olympic Committee, The Leukemia & Lymphoma Society, and The United States Cycling Federation.

# Table of Contents

---

Acknowledgments .....	6	Stems.....	74
Disclosure.....	7	Style Differences Summary .....	76
Table of Contents.....	8		
Just How Important is Bike Fit? .....	10	Part 3: Specialty Riding .....	77
How I Know—The Basis for Advice	11	Time Trialing .....	77
Rules of Thumb Summary.....	12	Climbing .....	81
		Sprinting.....	82
Part 1: Frames .....	13	Tandem Riding.....	83
Size .....	13	Mountain Biking.....	84
Top Tube Length.....	17	Specialty Differences Summary .....	85
Seat Tube Angle .....	19		
Crankarm Length .....	20	Part 4: Anatomical Considerations .	86
Custom Bikes .....	23	Leg-Length Discrepancy.....	88
		Arm-Length Discrepancy.....	91
Part 2: Bike Positioning.....	25	Part 5: Knee Alignment .....	92
Principles .....	25	Part 6: Wedges, Shims, Pedal	
Seat Height .....	27	Spacers, Orthotics, & Shoes.....	101
Seat Position Fore-Aft .....	40	Part 7: Pedal Stance Width, Stack	
Saddle Shape & Angle .....	45	Height, & Dropped Pedals .....	105
Foot/Pedal Fore-Aft.....	47	Part 8: Handling & Overlap .....	109
Foot/Pedal Rotation Angle .....	52	Part 9: Aches & Pains .....	111
Foot/Pedal Float .....	54	Part 10: Arnie's Differences.....	116
Foot/Pedal Side-to-Side.....	57	Part 11: Almost Final Words.....	117
Handlebars.....	58		
Brake Levers.....	63	Figured Your Bike Position? .....	118
Handlebar Angle.....	66		
Handlebar/Stem Height.....	67	Appendix A: Anatomy Glossary....	119
Torso Angle / Reach .....	68	Appendix B: UCI Bike/Fit Rules.....	123
Shoulder Angle.....	72	Appendix C: ABC Publications .....	127

*Within a perfectly acceptable range, choose a bicycle position to reflect your riding style, accommodate your anatomy, or treat an overuse injury.*

*Seat height is the holy grail of power.*

*Seat fore-aft is the holy grail of balance.*

*Torso angle is the holy grail of aerodynamics.*

*Fit the bike to the rider, not the rider to the bike.*

*All positions require adaptation. Good positions require less.*

## Just How Important is Bike Fit?

---

More or less than you might think.

I teethed into bicycle racing in the 1980s, watching the three M's: Merckx, Martens and Moser. Merckx, perhaps the greatest bicycle racer of all time, famously and typically changed his seat height many times during the course of a single ride.

On the other hand, I have ridden tandem with Floyd Landis for years. As long as I eyeball his seat height to within an inch of his usual position, he is happy. Happy to be training different muscles than he is used to, or happy because a new position may work away the pain from his hip replacement.

I have ridden tandem time trials for years. With some riders, it has taken scores of rides for my partner to adjust and get used to tandem positioning.

On the other hand, when I met Jane Gagne, we rode about 10 minutes one Saturday before she said: "Okay, I'm fine. That's enough." The next day we set the US mixed tandem 40-kilometer record.

I have fitted riders who have complained of nagging shoulder pain, related to cycling, for years. Observing a modest arm length difference, they have marveled that I have eliminated their pain by offsetting their brake levers by just a few millimeters (mm).

On the other hand, I have fitted track racers who have had two different length cranks (say a 165-mm on the left and a 170-mm on the right) for months or years without ever having noticed.

Sean Kelly's saddle position was low and his reach short by any current bike-fitting standard. Nonetheless, he was the world's number one racer for more than four years. Perhaps he could have been even better.

I believe a change in Sarah Hammer's position helped her. She had already won the 2006 World Track Pursuit Championships in April. Two months later, in June, I was asked to consult about her position. We lowered her aerobars, improving her aerodynamics. In October, at the US National Championships, she rode more than 4 seconds faster, setting a record in 3 minutes, 32.865 seconds.

Most people who ride bicycles never get a bike fit. Some high-end stores routinely offer comprehensive fits for all customers buying a new bike.

In my experience, almost everyone can benefit from a 5-minute or less eyeball fit. A club coach, an experienced bicycle store employee, or experienced rider can help.

If you are a performance athlete, an experienced bike fitter may help you improve your performance. An annual bike fit "check-up" may be a worthwhile investment.

If you have a bicycling-relating overuse injury, read the section on *Aches & Pains* on page 111. An experienced bike fitter, especially one with expertise in medical-grade bicycle fits, may help or cure your woes. A medical-grade fit may take an hour or more.

Regardless of your fitness or the presence of overuse injuries, reading this book may help your riding.

## How I Know—The Basis for Advice

---

I provide more information than many readers want or need. If so, skip the details. Read just the first few paragraphs of a topic, typically headed: “Rule of Thumb.”

Throughout this book, I let you know not only what my advice is, but why. I also let you know about alternative opinions.

Recommendations are made for one or more of the following reasons:

- *Tradition, conventional wisdom.* Sometimes recommendations are based on conventional wisdom. Parroting the advice of our teachers is common.  
Conventional wisdom example: Riders with a 32-inch inseam should ride 172.5-mm cranks.
- *Empiricism.* Experience. I have been a bicycle rider almost all of my life, a bicycle racer (Cat 1), and a coach for more than two decades. My coaching practice has extended from relative beginners hoping to complete their first century to Olympians. I am also a coaches’ coach, having trained more than 1,000 individuals. Where companies have provided me product at no cost or reduced cost, I disclose those companies, as on page 7. I sell no bicycle products and refuse kickbacks or commissions from manufacturers.  
Empiric example: Time trialists have the most power in a forward, high seat height position.
- *Logic,* including mathematical models.  
Logic example: Sprinters: Consider shorter cranks. Since the legs travel a shorter distance with each revolution, it makes sense that one may be able to spin faster cadences.
- *Scientific study.* Relatively few bicycle fit recommendations are based on solid scientific study. Much of what has been published has been of limited value, of a limited relevance, or provided little guidance. As is often the case, studies have provided seemingly contradictory results.<sup>2, 3</sup> Nonetheless, where scientific evidence exists, I let you know.  
Scientific example: Too low or too high a seat height worsens economy (metabolic cost).

---

<sup>2</sup> For example, at the Second Serotta Science of Cycling Symposium, it was reported that Maury Hull concluded that floating pedals are of no use in preventing knee injuries and that 10° of [valgus](#) canting was beneficial. Andy Pruitt concluded that floating pedals have greatly reduced knee injuries and that [varus](#) canting was beneficial. Zinn, L. VeloNews. Jan 29, 2008. [Linked and accessed Jan 30, 2008.](#)

<sup>3</sup> As one Tour de France champion, the recipient of conflicting advice, has said: “When we don’t have any problems, I wish these guys would stop trying to fix us and just let us ride our bikes.” Floyd Landis. Personal communication. Feb 6, 2008.

# Rules of Thumb Summary

---

The right size bicycle frame and components, and their adjustment, is important. Proper fit allows you to be comfortable, ride safely, and work effectively. It reduces or treats overuse injuries. Proper fit makes you a better rider.

## Bike Fit Rules-of-Thumb Summary

These and other bicycle-fit elements are discussed in detail throughout this book. There are numerous exceptions to almost all rules of thumb.

<b>Frame Size</b> Road: 2/3 inseam. Mountain: subtract 14 from inseam in inches.
<b>Cranks</b> Inseam to 31 inches: 170 mm. Inseam 31 to 33 inches: 172.5 mm. Inseam 33 or more inches: 175 mm.
<b>Seat Height</b> Knee bent 30° at bottom of pedal stroke.
<b>Seat Position Fore-Aft</b> Front of knee and pedal spindle in vertical line.
<b>Saddle Angle and Shape</b> Set level. Choose shape for comfort.
<b>Foot/Pedal Fore-Aft</b> Cleat axis between center and front of pedal axis.
<b>Foot/Pedal Rotation Angle</b> Point toes the way you walk.
<b>Handlebar Width</b> Road: width of the shoulders. Mountain: hands slightly wider than shoulders.
<b>Handlebar Shape</b> Select for comfort and riding style.
<b>Brake Levers</b> Tips in line with handlebar drops.
<b>Handlebar Angle</b> Point ends to middle of seat stays.
<b>Stem Height</b> Handlebar tops to at most a fist width below saddle.
<b>Torso Angle / Reach</b> Stem extension, height, and rise set at comfortable torso angle.
<b>Shoulder Angle</b> 90° with hands on hoods and elbows bent 15°.

# Part 1: Frames

---

## Size

---

You need the right-size bicycle so that you will be able to achieve correct leg extension, reach, and balance.

### Rules of Thumb

For a road bicycle, choose a conventional frame size that is two-thirds of your inseam.

For a mountain bike, subtract 14 from your inseam in inches.



**Figure 1. Measuring inseam. Measure from the floor to the top edge of a level or book snug against the crotch. Here, inseam is 30 inches.**

### Discussion

Frames are traditionally sized based on the length of the seat tube.

Determining your frame size is based on inseam measurement. To determine your inseam measurement, stand with your back to a wall with a level or the spine of a 1-inch-thick book against your inner leg, snug against your crotch.

Measure from the floor to the top edge of the level or book.

Most road racing bicycles are sold in metric sizes. One inch is 2.54 centimeters (cm). If you used inches, convert to metric by multiplying by 2.54. For example, if your inseam is 30 inches, or 76 cm, choose a 50- or 51-cm bike.

If a bicycle is too big or too small for you, you may lose control and fall.

## Other Methods

When you stand over a road bicycle in stocking feet there should be 0 to 1 inch of clearance from the top tube to your crotch, and about 1 to 2 inches when you are wearing shoes. If your crotch touches the top tube, the bicycle is certainly too big.

If you are sizing a mountain bike, you will need at least another inch of clearance over the top tube.



**Figure 2. Road bicycle frame size. Left: Allow at least 1 inch of clearance between the top tube and your crotch. Right: Compact road frames, like mountain bikes, will allow even more room.**

## Small Sizes

Small frames have more potential for the problem of toe overlap. When you turn the front wheel, your forward toe may hit the wheel and cause a crash.

If your road frame size is under 50 cm, consider a bicycle with 650c wheels (standard is 700c).

## Non-Traditional Sizing

The precise way in which manufacturers size their frames varies.

Traditionally frame size is the seat tube length from the center of the bottom bracket to the center of the top tube.

Some manufacturers measure either to the top of the top tube or to the top of the seat tube. For example, a traditionally measured 54-cm bicycle (center-to-center) is about 55 cm from the center of the bottom bracket to top of the top tube and 56 cm to the top of the seat tube.

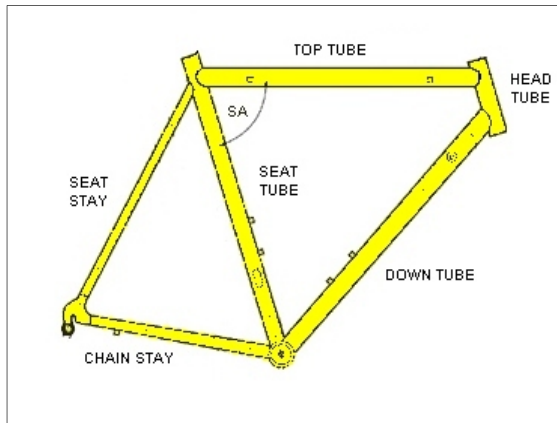

**Figure 3. Traditional road frame and component tubes. Also shown is the angle between the top tube and the seat tube, the seat tube angle (SA). SA is an important dimension affecting the seat position fore-aft and will be discussed on page 19 and page 40.**

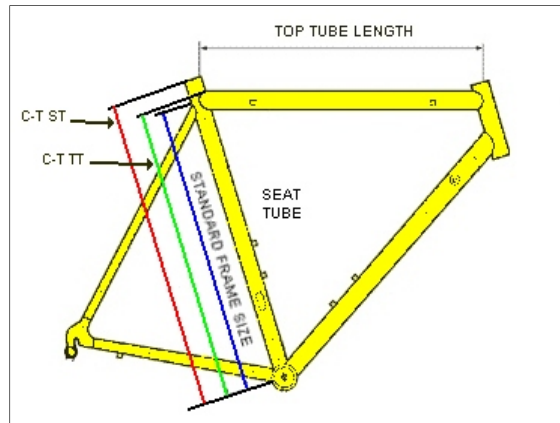

**Figure 4. Frame size. Traditional frame size is based on the distance from center of bottom bracket to center of top tube (BLACK). Some manufacturers base size on the distance from center of bottom bracket to the top of the top tube (C-T TT, GREEN) or to the top of seat tube (C-T ST, RED).**

Measuring to the top of the seat tube makes sense, especially for non-traditional frame designs with sloping top tubes or no top tubes.

It also makes sense to measure to the top of a virtual, or imagined, extension of the seat tube by a virtual horizontal top tube. Again, the issue is complicated: the measurement point of the virtual top tube may be at the center of where the top tube meets the tube, or at the top of the head tube (see Figure 5).

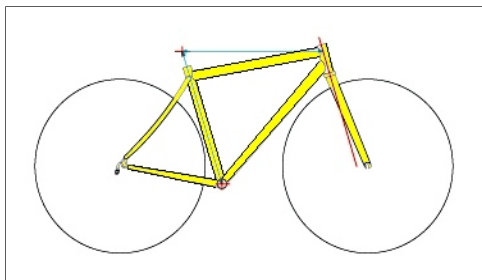
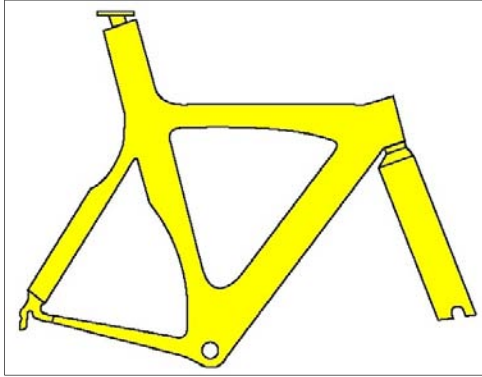

**Figure 5. Compact Litespeed frame sizes are based on the intersection of the virtual horizontal top tube and virtual seat tube. The actual size is based on the virtual seat tube length. The virtual seat tube is measured from the center of the bottom bracket shell to the point where the virtual top tube meets the centerline of the seat tube extending into the seat post region. The virtual top tube is the horizontal line parallel to the ground and extending from the point at which the centerline of the top tube meets the centerline of the head tube.**

Some non-traditional frame geometries do not lend themselves to any predictable size measurement (see Figure 6).

With improved material strength, compact frame geometry, and long seat tubes, it often makes sense to choose a frame based on top tube length.

Indeed some frame manufacturers size their frames based more on what the *top tube* length of their bicycles would be if the geometry of their bicycles were traditional. For example, a manufacturer may size a bicycle 58 that has exactly the same seat tube length as its 56 model, but a longer top tube.



**Figure 6. Assigning a size to this *Trek* time-trial frame is tricky.**

The multitude of non-traditional sizing methods makes it impossible to predict what size you will need for any given bicycle unless the sizing method is defined.

# Top Tube Length

Although frame size is the most important factor in choosing the frame that is right for you, different manufacturers may also have different length top tubes for the same size frame.

As stated above, with improved material strength, compact frame geometry, and long seat tubes, it often makes sense to choose a frame based on top tube length.

Where non-traditional frame geometries are used (compact bicycles, mountain bicycles—generally where there is a sloping top tube), or where there is no top tube (some monocoques), the top tube length is often imputed from a horizontal from where the top tube intersects the head tube to the seat tube or its seatpost extension. Some manufacturers measure from the center of the head tube top. Some frame geometries do not lend themselves to any predictable size measurement.

Some manufactures have “women-specific” models with shorter top tubes. Studies do not support the conclusion that women have shorter upper bodies and need relatively shorter top tubes than men need.<sup>4, 5, 6, 7, 8</sup> These frames may be a good choice for both women and men with shorter upper bodies.

Adjustment can be made to the effective length of the top tube (reach) by the use of handlebar stems of different lengths.

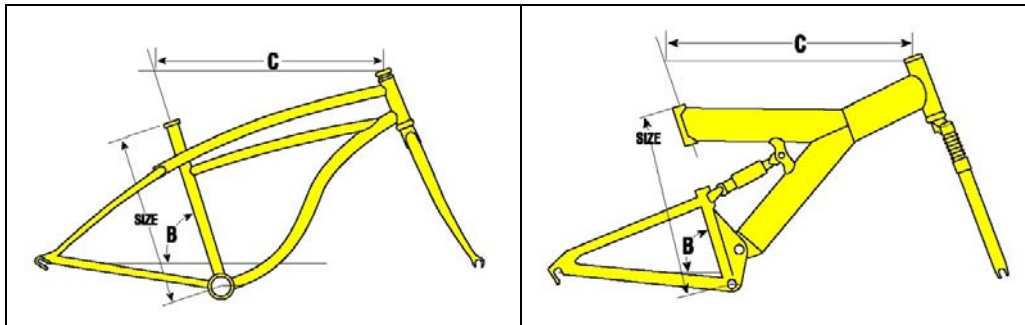

Figure continues below.

4 Contrary to the common belief of many, men have relatively longer legs than women do. Men have relatively shorter torsos than women do.

5 Tilley, AR. *The Measure of Man & Women*. John Wiley & Sons, Inc. New York. 2002.

6 Sokolovas, G. *Olympics Trials Summary Report. Anthropometrics*. [Accessed and linked Mar 16, 2009](#).

7 Bogan, B, et al. *The Relationship of Sitting Height Ratio to Body Mass Index and Fatness in The United States, 1988-1994*. Human Ecology Special Issue. (15): 1-8. 2007. [Accessed and linked Mar 16, 2009](#).

8 University of Wroclaw. *Adaptive preferences for leg length in a potential partner*. [Accessed and linked Mar 16, 2009](#).

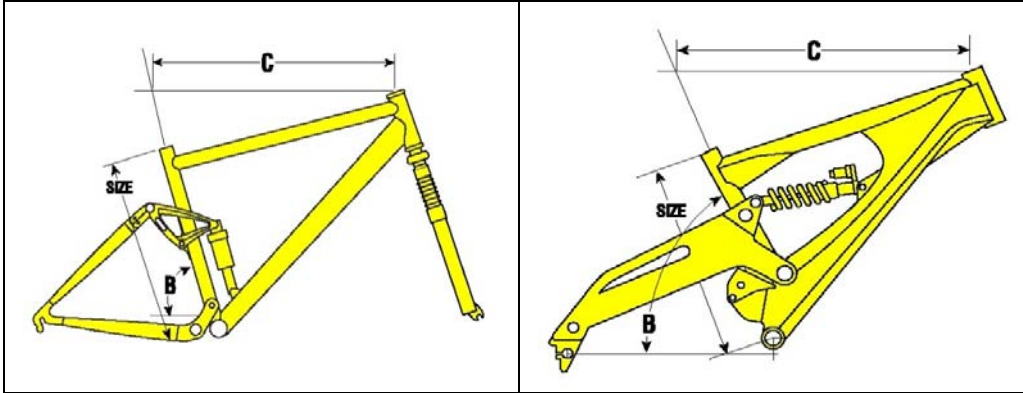

Figure 7. Top tube length (C). In non-traditional frame geometries, including those of almost all mountain bikes, the top tube length may be imputed from the horizontal distance from the head tube to the seat tube or its extension. Pictures: *Trek Bicycles*. Frame size and seat tube angle (B) are also indicated.

# Seat Tube Angle

The seat tube angle is the angle of the seat tube from the horizontal. A vertical seat tube has a 90-degree seat tube angle.

Seat tube angle, contributes to how far forward or aft of the bottom bracket the rider sits. For a fuller discussion of saddle fore-aft, see page 40.

For most riders, every degree change of seat tube angle changes fore-aft by about one-half inch.

Road bicycles typically have seat tube angles of about 73°; mountain bikes have seat tube angles of about 72°.

In general, the smaller the bicycle the steeper the seat tube angle—the higher the number.

The steeper the seat tube angle the more over the bottom bracket the rider sits. In general, the steeper the seat tube angle the harsher the ride and the more responsive the bicycle.

Track sprinters typically prefer steeper seat tube angles—say 75°. Recreational riders typically prefer shallower angles—say 72°.

Time trialists and triathletes often prefer steeper seat tube angles because the more forward position results in an opening up of the [hip angle](#) and more power.

However, steeper seat tube angles place more weight forward on the bicycle. They often handle relatively poorly, especially on descents.

Seat tube angles are indicated in Figure 3, Figure 7, and in Figure 8.

## Effective Top Tube Length

If two bicycles have the same top tube length and one has a steeper seat tube angle, when saddle fore-aft is set the same on both bicycles, the one with the steeper seat tube angle will have a longer effective top tube length.

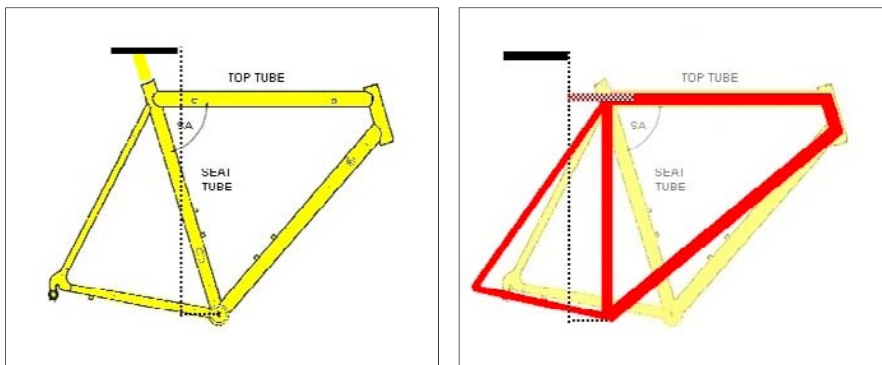

**Figure 8.** Left: YELLOW conventional road frame with 73-degree seat tube angle. Right: RED frame, with same length top tube, has 90-degree seat tube angle. To get the same saddle fore-aft (dotted black lines show equal saddle distance behind bottom bracket), the effective top tube length of the 90-degree frame is increased by the length of the checkered RED top tube line.

# Crankarm Length

---

## Rule of Thumb

Inseam to 31 inches: 170 mm crankarms.

Inseam 31 to 33 inches: 172.5 mm crankarms.

Inseam 33 or more inches: 175 mm crankarms.

## Discussion

There has been much debate, some empiric evidence, and little convincing scientific study to support the above recommendations.

Consider the wide variation in rider size (whether we measure trochanteric [leg length](#), inseam, or femoral leg length): a 5-foot rider differs from a 6-foot rider by about 20%. The roughly 3% small differences in commonly marketed crank lengths do not differ enough to make physiologic sense.<sup>9</sup>

Although it makes perfect sense for short riders (inseam less than 30 inches) on 700c road bikes or 26" mountain bikes to use 165-mm crankarms, and although most manufacturers make them, they are often special orders. Shorter crankarms are not produced in the lines of many major manufacturers, although they can be obtained from specialty manufacturers.

Although it makes perfect sense for tall riders (inseam more than 34 inches) on 700c road bikes or 26" mountain bikes to use 180-mm crankarms, and although some manufacturers make them, they are often special orders. Longer crankarms are not produced in the lines of most manufacturers, although they can be obtained from specialty manufacturers.

Track riders often choose crankarms up to 10 mm shorter and mountain bikers up to 5 mm longer than the above recommendations.

Shorter crankarms allow for faster cadences and improve cornering clearance on velodromes and in criteriums.

Although longer crankarms have been favored for hard steady efforts such as time trialing, hill climbing, and mountain biking, studies have shown that they change pedal force, not torque or power, as they require the rider to pedal a larger circle.

In time trialing in an aerodynamic position, longer crankarms mean that the knees rise higher, and hence closer to the chest—which may result in *worse* biomechanical function. The rider may close the [hip angle](#), *reducing* power.<sup>10</sup>

---

<sup>9</sup> A limited crankarm selection makes economic sense for component manufacturers.

<sup>10</sup> Some savvy riders flout tradition and use shorter crankarms for time trialing. For example, National time-trial champion and frame builder Glen Swann uses 165 mm, when he time trials.

## Background and Theory

### *Force and Optimal Crankarm Length*

Archimedes had a physics lesson for us when he said, “Give me a lever long enough and I will move the world.” What he failed to mention, was that as the lever grew longer, it would take longer to move the lever and the world.

Since (1) power is the time rate of doing work, or the product of force and velocity, and since (2) at a given bicycle speed, if the gearing hasn’t changed, the cadence remains the same... many coaches and authors have mistakenly concluded that the power requirements with longer cranks are also reduced.<sup>11</sup>

Studies have examined the pedal force required to maintain a given bicycle speed. Not surprisingly, less pedal force is required to turn the cranks when crankarm length is increased.

In rotational motion, power is equal to the product of torque and the angular velocity with which the torque is applied.

Torque is force times the perpendicular distance from axis to line of action of force.

Although the pedal force required is less, torque (and therefore power) for a given speed is the same, because torque is the product of force and crank length.

You may say: “But the leg force required is less, so either you should be able to save energy with longer cranks, or go back to applying the same force and then torque will increase, and longer cranks will allow you to apply more power.”

Again, this argument is wrong. The required force may be less, but the legs will have to travel farther around a larger circle, moving faster for a given rpm. You will not be able to maintain the same cadence, or the force you can apply will go down. Again, we are back where we began.

The bottom line is that the same studies that show a reduction in pedal force with longer cranks also show that *the power requirement does not change*.

From the limited studies available, examining pedal force, torque, or power has not helped us decide optimal crankarm length.<sup>12</sup>

---

11 Example: America’s most successful Olympic cycling coach, Eddie Borysewicz, misstated the science in his now-classic book *Bicycle Road Racing* (Vitesse Presse, 1985). “For a given gear ratio and pedaling cadence, it takes less power to maintain road speed as crankarm length increases.”

As the table he provided shows, what Eddie called power was *pedal force*. Power is the product of torque and rpm. *Torque*, the product of force x crank length, was, within the measurement accuracy, *the same* with all crank lengths.

Gear Ratio	RPM	Crank Length	Power/Pedal Force	Torque
48x14	117.1	165	30.89	5096.85
		170	29.98	5096.60
		175	29.13	5097.75

Changing crank length does not change torque or power required to travel a given speed. First four columns from Borysewicz. Last column, Torque, calculated from the product of columns 3 and 4, crank length x pedal force.

12 At the Second Serotta Science of Cycling Symposium, it was reported that Jim Martin found no difference in maximal sprint power using 120, 145, 170, 195, and 220 mm cranks. Zinn, L. VeloNews. Jan 29, 2008. [Linked and accessed Jan 30, 2008.](#)

## Cadence

Empirically, it is well known that shorter cranks allow for faster cadences. Where distance traveled is proportional to cadence, rather than power, shorter cranks win out.

For this reason, roller races often set a lower limit on crankarm length of 165 mm.

Logically, shorter cranks mean that the legs do not travel as far per pedal revolution, and so more revolutions can be accomplished per minute.

Shorter cranks have other benefits that improve cadence:

- If shorter cranks are used, the knee arc, as defined and described in Figure 15 on page 32, will also be shorter. This will be true regardless of whether the seat height is adjusted to reflect the same degree of knee flexion at the bottom of the pedal stroke.
- If shorter cranks are used, the [hip angle](#) will be larger (more open) at the top of the pedal stroke. The leg will not rise up as far at the top of the pedal stroke. This will also be true regardless of whether the seat height is adjusted to reflect the same degree of knee flexion at the bottom of the pedal stroke.

<b>Crankarm Length (Mm)</b>	<b>Knee Flexion Angle Bottom of Stroke</b>	<b>Knee Arc</b>	<b>Hip Angle Top of Stroke</b>
<b>No Change in Seat Height</b>			
165	32.4	31.20--Shorter	40.3—More Open
170	30	32.51	39.7
175	27.4	33.89--Longer	39.2—More Closed
<b>Change Seat Height</b>			
165	30	31.77--Shorter	40.8—More Open
170	30	32.51	39.7
175	30	33.25--Longer	38.7—More Closed

**Table 1. Changing crankarm length: Regardless of whether seat height compensates for a change in crank arm length or not, shorter cranks always result in a shorter knee arc, a more open hip angle, and potential for higher RPM. Baseline value is 170 mm crankarm length with a knee flexion angle of 30° at the bottom of the pedal stroke. For other methodology and assumptions, see Figure 15 and description on page 32.**

## Acceleration

Conventional wisdom has it that shorter crankarms allow one to accelerate more quickly. This is the approach of velodrome racers.

This opinion is not universal. Some riders report that longer crankarms accelerate more quickly but that high rpm cannot be maintained.

BMX riders traditionally use long crankarms. For example, here is a typical sizing chart.<sup>13</sup>

<b>Inseam</b>	27"	28"	29"	30"	31"	32"	34"
<b>Crank Length</b>	171	175	177	180	182	185	190

**Figure 9. Typical BMX crank sizing chart.**

<sup>13</sup> From Wiregrass BMX. [Linked and accessed Jan 14, 2008.](#)

# Custom Bikes

---

Most riders do not need bicycles with custom dimensions.

Riders generally need custom bicycles when they require a bicycle with longer or shorter top tubes relative to frame size. That is to say when their reach is out of normal proportion to their [leg length](#). Improved material strength and longer seat posts make this situation less common today than years ago.

For the purposes of discussion here:

- Leg length is the distance from the ground to the greater trochanter of the femur.
- Bicycle reach is a combination of torso and arm length. With the hand comfortably straight up over the head, bicycle reach may be defined as the distance from greater trochanter to the first webspace, the crotch between the thumb and second finger.

Comfortably straight up over the head means not hyperextending: the elbow is a few degrees short of full extension and the shoulder on the extending side is level with the shoulder on the non extending side.

- Reach height is leg length and bicycle reach.

The leg-length to reach-height ratio is about 42% for normally proportioned riders.

When racers' lower body to total reach proportions are less than 40% or more than 45%, they may need a custom frame.

Since beginners and recreational riders tend to sit more upright, their effective reach is shorter.

When riders who prefer a [torso angle](#) of 60° have a lower body to total reach ratio of more than 44%, they may prefer a custom frame.

Riders whose reach is disproportionately shorter than their leg length, whether male or female, may still be able to ride stock bicycles if they find frames with relatively short top tubes, sometimes marketed as having “women’s-specific” geometries.

Such bicycles are often also a good choice for beginners, recreational riders, and obese riders who prefer a more upright position.

Some manufacturers specialize in stock bicycles proportioned for tall riders.

Riders who require frames less than 50 cm may find that their toes overlap the front wheel when they turn the bicycle, and may require a bicycle with custom geometry to avoid this safety problem.



**Figure 10.** The ratio of leg length to total reach is normally about 42%. The rider points with his right middle finger to the bump of the greater trochanter of the femur.

### **Other Methods**

If your arm span is within 1 inch of your height, height divided by inseam will give a good measure of your bicycle reach.

If height divided by inseam is more than 2.2, you have a relatively long torso. You will need a bicycle with at least as long a top tube as your frame size.

If height divided by inseam is less than 2.0, you have relatively long legs. You will need a bicycle with a top tube at least 2 cm shorter than your frame size.



**Figure 11.** Arm span vs. height.

# Part 2: Bike Positioning

---

## Principles

---

### Fit Window

For most riders, there is a “fit window,” or range of perfectly acceptable bicycle positions. Position is a compromise. Position is different for optimizing muscle power, aerobic efficiency, comfort, bicycle control, and minimizing injury.

Position may be modified within the fit window in response to overuse or traumatic injuries.

Here are some simple ways to make sure your position is within an acceptable fit window.

### Be Safe

Never make adjustments to bicycle parts that extend them beyond their safe limits. The stem and seatpost normally have limit lines marked with either “maximum extension” or “minimum insertion” warnings.

Be certain to tighten bolts properly after making adjustments. Many bike fit problems and mechanical failures result from parts slipping from incomplete tightening or breaking from over tightening.

### Make Modest Modifications

Seasoned riders have adapted to their positions, whether good or bad.

To prevent overuse injuries, especially when adjusting seat height, generally make modifications gradually, allowing time to adapt to new positions.

Do not change seat height more than 3 mm (1/8 inch) every 300 miles.

Another option, less commonly used, is to immediately fit the “best” position, and then ride a limited volume and intensity. Gradually increase duration and ride difficulty until adapted.

### Set-Up, Tools

You or your position adviser (bicycle shop seller, frame builder, friend, or coach) can approximate good bicycle fit by a quick road test.

For a more precise fit, set the bicycle on a trainer. Level the bicycle with a trainer block or an about two-inch block of wood under the front wheel. If the bicycle has a top tube parallel to the ground when off the trainer, the top tube should be parallel to the ground on the trainer.

You will need bike tools, a plumb line or straightedge, a level, a tape measure, calipers, and a recording sheet and pen. An assistant, a goniometer (angle-measuring device), a calculator, and a clipboard are helpful.

## **Warm Up**

Riders ride differently when warmed up.

Pedal at least moderately hard for 10 minutes before making adjustments.

Pedal moderately for a few minutes between adjustments.

Riders ride differently during hard efforts.

A comprehensive fit includes observing riders during maximal ramped power and sprint efforts.

## **Where to Start**

The order in which you perform adjustments is important since some measurements are dependent upon others. The order used in the following pages works best for most riders.

# Seat Height

---

Seat height is the most important bicycle-position setting.

*Seat height is the holy grail of power.*

Many non seat-height bike-positioning recommendations are often work-arounds to mitigate a suboptimal seat height.<sup>14</sup>

After seat height is initially set, it may need to be adjusted if cleat fore-aft, seat fore-aft, cleat thickness, pedal height, crankarm length, shoes, or saddle are changed.

## Rule of Thumb

Set the seat height so that the knee is flexed about 30° at the bottom of the pedal stroke. Power riders may set the saddle higher. Beginners may set the saddle lower.<sup>15</sup>



**Figure 12. Seat height.** A seat height that results in 30° of knee flexion is a good compromise for many riders. Red dotted anatomical landmarks, from the top: Greater trochanter of hip, lateral condyle of knee, lateral malleolus of ankle. Racers may prefer a higher position. Beginners may prefer a lower position.

---

14 For example, suggestions to move the seat back for anterior knee pain (patellofemoral dysfunction), or use medial wedges for medial knee pain (anserine tendonitis), or move the cleats back for time trialing, or use longer cranks for time trialing, may merely be substitutes for raising the saddle. Suggestions to move the seat forward for iliotibial band pain or hamstring strain, or move cleats forward for sprinting, may really be substitutes for lowering the saddle.

15 Genzling, C. Claude, in the 1970s, was one of the first authorities to popularize and set seat height not only by inseam formulas but also by knee flexion at the bottom of the pedal stroke, advocating 25° to 30° of knee bend.

## Discussion

Set seat height based on knee flexion (leg extension):

Angles are measured in degrees of flexion from a straight leg (this is the same as the number of degrees short of full extension).

By convention, knee angles are measured when the leg is at the bottom of the stroke (6 o'clock position) and the foot is horizontal. The angle is determined by the greater trochanter of the hip (femur), the lateral condyle of the knee (femur), and the lateral malleolus of the ankle (fibula).

For an illustration of lower limb bones and landmarks, see Figure 87 on page 121.

This conventional method is practical because it is easy to have the crank vertical and the foot horizontal.

However, this method has minor drawbacks because it may not account for effective seat tube angle and ankling (ankle motion). Although positioning the shoe horizontally standardizes the measurement, not all riders pedal flatfooted. Many riders pedal toe down; some drop their heels while pedaling.

Too low a saddle is one of the most common fit errors and is associated with pain in the front or sides of the knee. Front of the knee pain is the most common knee overuse injury I see. A low saddle can exaggerate the natural knees-in or knees-out riding style inherent in any given rider, and so contribute to both inside of the knee (medial) and outside of the knee (lateral) knee pain. For more about knees-in and knees-out pedaling styles, see page 92.

Too high a saddle is associated with back of knee, outside of the knee (lateral), hamstring, and Achilles pain.

This standard method of measuring knee angles may need to be modified depending upon rider style.

Many riders come forward for hard effort on level ground or when sprinting, effectively increasing knee flexion.

Time trialists come forward because the loss of leg extension and power is more than compensated for by the opening up of the [hip angle](#). This is not ideal: better is to come forward *and* raise the saddle. Read more about time-trial position on page 77.

Since acceleration and fast cadence is a requirement for sprinters, this makes sense when the tradeoff in power is the ability to increase rpm. Read more about sprinting on page 32.

Professional riders often prefer a slightly lower seat height to help keep balance when jostling in large packs.

When seat height, conventionally measured along the seat tube, is set by formulas based on inseam or leg length, moving the cleats forward or back effectively decreases or increases seat height. However, cleat position may not be the reason why sprinters like a forward cleat position and time trialists a rearward one. As you may read starting on page 32, the reason may have more to do with seat height.

Generally, the higher the saddle the more power you can generate, and the less the aerobic cost. However, too high a saddle may cause your hips to rock—wasting energy and thereby worsening economy (metabolic cost)—or restrict your leg speed, your ability to pedal fast cadences.

Seasoned racers tend to have more of a toe-down pedaling style. Beginners and recreational riders tend to pedal more flat-footed.

For this reason, a racer may have the same knee angles while pedaling the bicycle with a higher saddle position.

- Beginners, recreational riders, sprinters, mountain bikers, and those with tight hamstrings prefer a knee angle about 30° of knee flexion.  
For a discussion about why a lower saddle may improve sprinting, see page 32.
- A knee angle of 25° to 30° knee flexion is a good compromise between performance and injury prevention for seasoned racers.

Time trialists, especially those with good back and hamstring flexibility, may fit at knee angles just 10° knee flexion in part because their angles increase as they come forward on the saddle when pedaling at time-trial pace. For examples of minimum knee flexion and time trial set-up, see Figure 57 on page 77, or Figure 61 on page 83.

Since mountain bikes have a higher bottom bracket than road bicycles, and since bicycle control and center of gravity is a little better with the saddle slightly lower, mountain bikers adjust their seat height down to allow up to 5° more flexion in the knee.

Since it is easier to develop high rpm with a saddle slightly lower, sprinters may also prefer to adjust their seat height down to allow up to 5° more bend in the knee. Read more about this starting on page 32.



**Figure 13.** Mountain bikers often prefer a slightly lower saddle than road riders do. The center of gravity is lower and bicycle control may be improved. Riders are able to more easily move backward and forward on their saddles on descents and climbs to improve traction.

## Other Methods

### *Knee Angle Variations*

Authorities have recommended knee flexion angles between 25° and 44°. <sup>16</sup>

Some authorities align the crank with the down tube. Aligning the crank with the down tube generally extends the knee a few degrees more.

Not all bicycles have simple, straight down tubes that allow the crank to be precisely positioned. Not all riders sit center-aligned with the down tube; many are forward or rearward of this position. Many riders sit back on the saddles when climbing, effectively extending their legs and decreasing their knee flexion.

Some authorities do not use standard anatomical landmarks, centering the goniometer on “the middle of the knee” and tracking the crankarms along the axis of the leg and of the thigh.

### *Formulas*

Formulas based upon inseam measurements or other body dimensions can only give approximate results and can only provide starting points. <sup>17</sup> Cleat fore-aft, seat fore-aft, cleat thickness, pedal height, shims and orthotics, crankarm length, seat tube angle, foot length, and pedaling style are often not considered in such formulas.

Most popular formulas are based on studies of racing cyclists, decades old, developed before the use of clipless pedals.

If formulas are based on scientific study, they are usually based on trochanteric [leg length](#) or inseam, and on minimizing oxygen consumption. Formulas have not generally been based on injury prevention, maximizing power output, or maximizing leg speed. <sup>18, 19, 20, 21, 22, 23.</sup>

---

16 John Howard recommends a flexion angle between 30° and 44°. Personal communication Feb 3, 2008.

17 Peveler, in a study of 19 riders, showed that setting seat height by 88.3% of inseam (the LeMond method), results in knee flexion from 14° to 42°. Using 109% of inseam results in knee flexion from 9° to 42°. Using the heel-on-pedal method results in knee flexion from 21° to 42°. Peveler, W et al.

*Comparing methods for setting saddle height in trained cyclists.* Journal of Exercise Physiology. 8. (2005).

18 Gonzalez, H and Hull, ML. 97% of trochanteric leg length. Results in the least oxygen consumption.

*Multivariable optimization of cycling biomechanics.* J. Biomechanics. 22 (11/12). 1151-1161. (1989).

19 Guimard, C and LeMond, G. 88.3% of inseam equals seat height to bottom bracket.

20 Hamley, EJ and Thomas, V. *Physiological and postural factors in calibration of the bicycle ergometer.* J Physiol. 91(2). 5-56. (1967). 109% of inseam or 100% trochanteric leg length equals seat height to pedal.

21 Hodges, M (1982). Reported by Borysewicz, E. *Bicycle Road Racing.* Vitesse Press. Page 47. (1985).

96% of trochanteric leg length equals seat height to pedal spindle. Account for and subtract cleat thickness and half pedal thickness. Results in the least oxygen consumption.

22 Nordeen-Snyder, K. *The effect of bicycle seat height variation upon oxygen consumption and lower limb kinematics.* Medicine & Science in Sports & Exercise. 9. 113-117. (1977). 105% of trochanter leg length.

23 Shennum, PL and deVries, HA. *The effect of saddle height on oxygen consumption during bicycle ergometer work.* Medicine & Science in Sports & Exercise. 8. 119-121. (1976). 100% of trochanteric leg length.

My preferred easy-to-remember, rough rule-of-thumb formula is that the distance from the center of the bottom bracket along the seat tube to the top of the saddle should be 90% of inseam measurement for racers, a little lower for recreational riders.

### ***Heel on Pedal***



**Figure 14. Yellow ring encircles the heel on the pedal.**

Some set the seat height so that the heels just touch the pedals at the bottom of the pedal stroke.

This method tends to give lower seat height than most formulas.

Again, this method has problems because cleat fore-aft, seat fore-aft, cleat thickness, pedal height, shims and orthotics, and pedaling style are not considered with this rule.

### ***As High as Possible***

Since power improves as seat height increases, some riders purposefully raise their saddles too high—then lower the saddle so that they can (1) reach the pedals (not rock), (2) have enough leg speed to sprint, or (3) prevent/treat an overuse injury.

### ***Rocking***

Rocking the hips while pedaling can be a sign that the saddle is too high. Nevertheless, everyone rocks at pedal cadences faster than their neuromuscular fitness, and some riders rock no matter what their seat height.

## Why a Lower Saddle Improves Sprinting

The ability to spin at a high cadence is one of the attributes of an excellent sprinter. (Peak power, tactics, and skill are others.) Keep in mind a low position sacrifices economy (metabolic cost) and steady-state power. Read more about this on page 35.

A lower saddle makes it easier to achieve a high cadence.

### *Prove it Yourself*

You can prove this to yourself easily. You will need a cadence computer. Mount your bicycle on a stationary trainer. After a 15-minute warm-up, pedal in your easiest gear with a cadence of about 80 rpm. Increase cadence 5 rpm every 15 seconds until you max out. Now lower your saddle 1 cm (about half an inch). Perform the same test. See how fast a cadence you can work up to. Repeat the test with the saddle back at its higher position. Most riders can spin faster at the lower saddle position.

### *Trigonometry Helps Explain It*

Here is one explanation why a lower saddle improves leg speed:

The leg travels a shorter distance when the saddle is lowered, and so more revolutions per minute can be generated.

For math buffs, here is the basic trigonometry. Please see Figure 15.

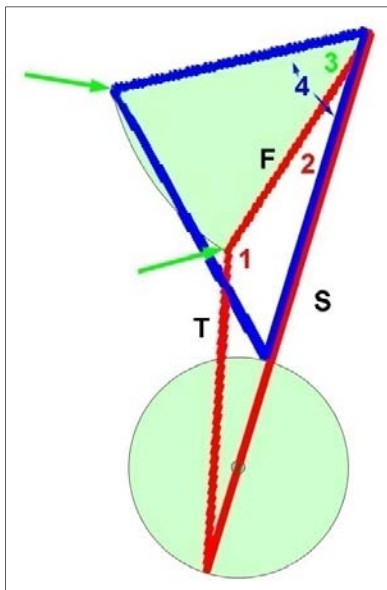

Figure 15. Schematic representation of the hip, knee, and foot position at the top and the bottom of the pedal stroke. F = femur. T = tibia. S = saddle to pedal segment. Red triangle diagrams the bottom of the stroke. Blue triangle diagrams the top of the stroke. The green pie slice and arc between arrowheads represents the distance the knee moves. The green circle represents the pedal circle. See text.

For relative simplicity, assume that:<sup>24</sup>

The leg is represented by a femur segment (F) and tibia segment (T).

The S segment distance is the distance from the saddle to the pedal. It is close to seat height, plus or minus the crank length, depending upon whether one is considering the bottom (red triangle) or top (blue triangle) of the pedal stroke.

The upper end of the thigh is fixed to the pelvis, attached at the hip.

The knee moves in a circular arc, the radius of which is determined by the length of the femur.

The length of the arc (between the green arrowheads in the figure) is shorter when the saddle is lower.

### *Detailed Calculations*

Assume a femur (F) segment of 40 cm (about 16 inches) and a tibia (T) segment of 50 cm (about 20 inches). The tibia segment includes the length of the foot.

If the seat height is set so that the knee has 25° of flexion, the **Red Triangle Angle 1** will be 155°. The **Red S** segment can be calculated. It is 87.9 cm (about 34 inches), representing seat height plus crank arm length. If crank length is 17 cm (170 mm, about 6-3/4 inches), then seat height is about 70 cm (about 27-1/2 inches). The value can be calculated based on the cosine rule, as applied in this situation:  $S^2 = F^2 + T^2 - 2(F)(T)(\cosine\ 155)$ . The cosine rule will allow many of the calculations that follow.

The **Red Triangle Angle 2** can now be calculated. It is 13.9°.

Once the S segment at the bottom of the pedal stroke is known, the corresponding segment length at the top of the stroke is this value minus twice the length of the crank arm. As the crankarms are 17 cm (170 mm) the corresponding **Blue S** segment will be 53.9 cm.

Now **Blue Angle 4** can be calculated. It is 62.3°. The **Green Angle 3**, by subtraction, is 48.4°.

Now the **Green Arc** distance between the **Green Arrows** can be calculated. It is 33.8 cm. The value can be calculated based on arc's percentage of the formula diameter =  $2\pi$  (radius). Here the distance =  $2\pi(40)(48.4/360) = 33.8$ .

Consider the situation if the seat is lowered so that the knee has 35° of flexion. This will be about 2 cm lower. The **Green Arc** distance will be 31.4 cm.

The **Green Arc** distance is 2.4 cm shorter, about 7 % of the original length.

If leg speed is the issue, other things being equal, a rider might be expected to be able to pedal about 7 % faster.

---

24 Yes, it is simplistic. The affect of ankling (ankle motion) and its interaction with cadence is ignored. The upper end of the femur segment is above the seat height. Pedal/cleat/shoe thickness is not considered. There is a difference between 30° of knee flexion at the bottom of a pedal vertically aligned with a seat set back 17° (seat tube angle 73°) rather than when the pedal is aligned with the seat tube. Motion outside the **sagittal plane** is not considered. Nonetheless, complicating the model will not change the relationships shown.

Knee Flexion Angle	Seat Height (cm)	Knee Arc (cm)	Result	Possible Effect
15	72.2	36.7	Longest Distance	Slowest RPM
20	71.7	35.2		
25	70.9	33.8		
30	70.0	32.5	Intermediate Distance	Intermediate RPM
35	68.9	31.4		
40	67.6	30.3		
45	66.2	29.4	Shortest Distance	Fastest RPM

**Table 2.** As the seat height is lowered and the knee bend at the bottom of the stroke increases, the knee travels a shorter distance as the foot moves from the bottom to the top of the pedal stroke. Leg speed may improve. Here the distance the knee travels is based on an assumed femur (thigh) segment of 40 cm, a tibia (leg and foot) segment of 50 cm, and a crank length of 170 mm. See text discussion.

### *Moving the Cleat Back May or May Not Change Leg Speed*

As discussed beginning on page 47 and specifically in reference to arch cleats on page 50, moving the cleats back on the shoe may worsen leg speed ability if seat height is based on inseam or leg length.

However, if seat height is based on knee flexion at the bottom of the pedal stroke, the knee arc will be shorter and leg speed ability may improve modestly. To help understand this principle, use the model described above. Consider the foot an extension of the lower leg, simplistically ignoring ankle.

Consider a rider with knee flexion of 30° at the bottom of the pedal stroke and a seat height of 70 cm (about 27-1/2 inches):

Moving the cleat back 2 cm (about 13/16 inch) will *increase* the knee arc about 2.9 cm if the saddle is not lowered. This might be expected to *worsen* leg speed.

Moving the cleat back 2 cm *and* lowering the seat to compensate—to have the same flexion angle at the bottom of the pedal stroke—will *decrease* the knee arc about 0.4 cm and might be expected to modestly *improve* leg speed.

Row	Lower Leg Segment (cm)	Knee Flexion Angle	Seat Height (cm)	Knee Arc (cm)	Possible Effect
1	50	30	70.0	32.5	Standard Leg Speed
2	48	18	70.0	35.4	++++ Slower RPM
3	48	30	68.1	32.1	+ Faster RPM

**Table 3.** From a standard position (Row 1), moving the cleat back might be expected to worsen leg speed performance if the seat height is not changed (Row 2). It might be expected to modestly improve performance if the seat height is lowered proportionally (Row 3).

## A Higher Saddle Improves Power and Economy—To a Point

*Seat height is the holy grail of power.*

*A low seat height robs power on both the downstroke and upstroke.*

It is difficult to predict precisely from biomechanical models how seat height affects power. The issue is complex. It involves multiple muscles, the variable attachment points of the muscles on bones, resting muscle length, complex joint interactions with six degrees of freedom, and the absolute and relative length of the bones. Cadence is also a consideration. This issue is one where “one test is worth a thousand expert opinions.”<sup>25</sup> Moreover, as is usually the case in science, we need more than just one test. Unfortunately, there has been little scientific study of seat height and power.

I believe a higher saddle improves power not so much because of what happens at the *bottom* of the stroke but because of what happens at the *top* of the stroke: the closure of the [hip angle](#).

Consider two classic bicycling leg strength-training exercises: squats and step-ups.

Power lifters know one can lift heavier weights performing quarter squats than half squats, and lift heavier weights in performing half squats than full squats. A power lifter might quarter squat 800 pounds, half squat 650 pounds, and full squat 525 pounds.<sup>26</sup>

One can lift more weight up a 14-inch step than a 20-inch step.

When the knee and hips flex, when the knee and hip angles close, there is less strength.

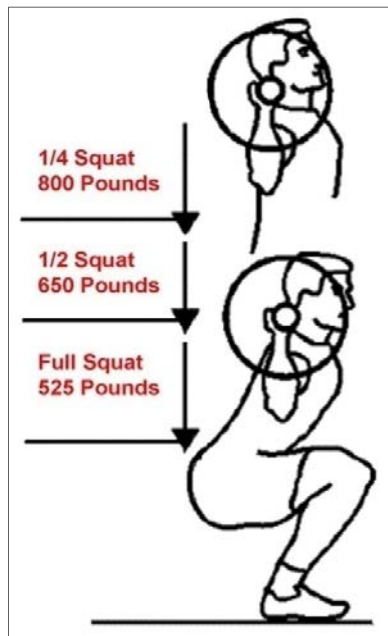

**Figure 16. The more the hips and knees bend, the less the weight that can be lifted. It is the same on the bike: The more the hips and knees bend, the less the power that can be developed.**

25 Attributed to German rocket scientist Wernher von Braun.

26 Thibodeau, C. *Band training for big gains*. t-nation.com. (2004) [Linked and accessed Jan 19, 2008](#).

As shown in Table 4, when seat height is lowered, the hips and the knees bend more. With more bend, less power can be developed.

Seat Height (cm)	Knee Flexion (Degrees) Bottom of Stroke	Knee Flexion (Degrees) Top of Stroke	Femur Angle (Degrees) Top of Stroke	Hip Flexion (Degrees) Top of Stroke	Result
72.2	15	120.4	12.1	97.9	Least Bend, Most Power
71.7	20	120.7	11.5	98.5	
70.9	25	121.1	10.7	99.3	
70.0	30	121.6	9.7	100.3	Intermediate Bend
68.9	35	122.2	8.4	101.4	
67.6	40	122.9	7.3	102.7	
66.2	45	123.6	5.8	104.2	Most Bend, Least Power

**Table 4.** As the seat height is lowered and the knee bend at the bottom of the pedal stroke increases, the hip and knee flexion increase at the top of the pedal stroke—resulting in less power. The model/table is based on a femur (thigh) segment of 40 cm, a tibia (leg and foot) segment of 50 cm, and a crank length of 170 mm. Hip flexion angle assumes 20° of pelvic tilt.<sup>27</sup>

Loss of power relates not only to increased bend in the hips and the knees. The more the body (torso) is bent over, the more the hip angle (the angle formed between the femur and the torso) closes. Closure of the hip angle is also associated with a loss of power, independent of hip flexion (the angle formed between the femur and the pelvis).

Seat Height (cm)	Knee Flexion (Degrees) Bottom of Stroke	Hip Angle (Degrees) Top of Stroke	Result
72.2	15	42.1	Open Hip Angle, Most Power
71.7	20	41.5	
70.9	25	40.7	
70.0	30	39.7	Intermediate Hip Angle
68.9	35	38.6	
67.6	40	37.3	
66.2	45	35.8	Closed Hip Angle, Least Power

**Table 5.** As the seat height is lowered and the knee bend at the bottom of the pedal stroke increases, the hip angle closes at the top of the pedal stroke—resulting in less power. The table is based on an assumed femur (thigh) segment of 40 cm, a tibia (leg and foot) segment of 50 cm, a crank length of 170 mm, a torso angle of 30°, and a 73 degree seat tube. For more information about torso angle, see page 68.

<sup>27</sup> Hip flexion is the flexion of the femur with respect to the pelvis. If the pelvis is anteriorly tilted, flexion increases. Pelvic tilt is not readily measured and differs between riders. Femur angle is easily measured, or computed as in the modeling here. It equals (90 + pelvic tilt – hip flexion) degrees.

Sauer et al showed that males have about 21° and females about 24° of pelvic tilt. Sauer, JL et al. *Influence of gender, power, and hand position on pelvic motion during seated cycling*. *Medicine & Science in Sports & Exercise*. 39 (12). 2204-2211. (2007). [Linked and accessed Jan 27, 2008.](#)

### ***Prove it Yourself***

You can prove the importance of hip angle to yourself easily. A cadence, speed, or power computer is helpful, but not necessary.

Mount your bicycle on a stationary trainer.

After a 15-minute warm-up, unclip one of your feet, and pedal with one leg. Rest the other leg on the back of your trainer.

With your hands on the tops, pedal in a moderate gear with a steady cadence, say at 60 rpm.

After one minute, change your hand position to the drops.

Continue pedaling in the same moderate gear, still at the same steady cadence.

After another minute, return to the tops.

The tops are easier, aren't they?

The reason: When bent over in the drops, the hip angle closes, and power is lost. That is why seated climbers do not climb in the drops. (On level ground, sometimes the power lost is more than made-up for by improved aerodynamics).

### **Hip Angle Economics**

As discussed above, a lower saddle improves leg speed. However, a lower saddle may worsen economy—it may take more oxygen to provide the same power. This may worsen steady-state performance in climbing or time trialing.

Economy in sport science is similar to economy for your car. Economy relates to fuel efficiency, miles per gallon. It is one of many important aspects of human performance.

Most studies of the 1970s and 1980s noted that by raising seat height, oxygen consumption was minimized. Most riders used to ride too low for optimal economy. For example, Edward Borysewicz noted in his now classic *Bicycle Road Racing*, that his Junior National Coach Mark Hodges found that economy was improved, for a majority of riders tested, by raising their seat height.<sup>28</sup> He also noted that this optimal height was higher than the traditional heels-on-pedals method.

Economy relates not only to changing seat height and the resulting change in hip angle. Economy relates also to the changes in hip angle with the same seat height. In one study, aero-position oxygen cost was 1.5 mL/kg/min and heart rate 5 beats per minute higher compared with upright cycling.<sup>29</sup>

### ***A Simple Test May Show Why Raising Seat Height Improves Economy***

Try this: Stand on one leg. Lift the knee of your other leg up. Raise it as high as you are completely at ease and comfortable. Do not force things; do not try to raise your knee up as high as you possibly can.

If you are like most people, you can comfortably raise your knee so that your hip forms an angle with your thigh and torso of about 90°. If you work it, you may be able to raise your knee another 20° or so, to about 110° of flexion. If you lie down, flat on your back, and use your hands to pull your knee toward your body, you may achieve another

---

28 Edward Borysewicz. *Bicycle Road Racing*. Vitesse Press. Page 47. (1985).

29 Gnehm, P, et al. *Influence of different racing positions on metabolic cost in elite cyclists*. *Medicine & Science in Sports & Exercise*. 29 (6). 818-823. (1997). [Linked and accessed Jan 27, 2008](#).

25° or so of motion, for a total of 135° of flexion—the normal range of motion for young, healthy, uninjured, non-arthritic adults.

The message: it takes muscular work to bend your hip more than 90°.

In some ways, raising the knee is like a cartridge in a spring-loaded ballpoint pen. The cartridge slides in easily until it meets the spring. Then more pressure (energy) will slide the cartridge in further against the spring. Finally, the limit is reached.

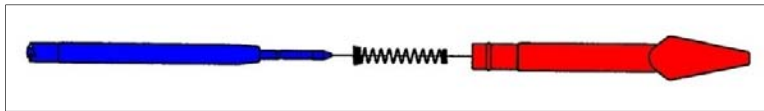
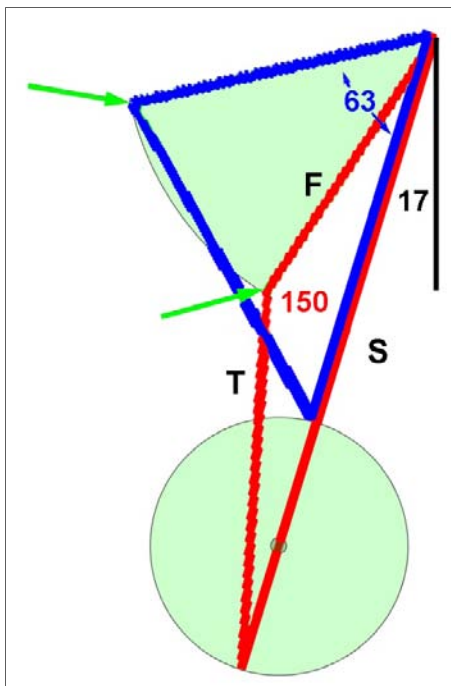

**Figure 17. Cartridge (blue) slides easily into nose body of ballpoint pen (red) until it meets spring. Pressure will push it in further.**

Now repeat the standing test. This time before raising the knee, bend about 60° forward at the waist. Now raise your knee. Keep track of how far you raised your foot, stand up straight, and with the knee raised to the same position measure the angle of hip flexion. It is less, perhaps 75°.

The message: it takes considerably more muscular work to bend your hip more than about 75° when you are bent over about 60°, typical for a bicycle rider.

Now look at Figure 18 and Table 6.



**Figure 18. Hip flexion angle. In this model, with a seat tube angle of 17°, a level pelvis and saddle, and 30° of knee flexion at the bottom of the pedal stroke (knee angle 150°), the hip will flex 80° (63° + 17°) at the top of the pedal stroke.**

Seat Height (cm)	Knee Flexion Angle Bottom of Stroke	Hip Flexion (Degrees)	Result
72.2	15	97.9	
71.7	20	98.5	
70.9	25	99.3	Best Economy
70.0	30	100.3	
68.9	35	101.4	Intermediate
67.6	40	102.7	
66.2	45	104.2	Worst Economy

**Table 6. Hip flexion. As seat height is lowered, (1) the knee bend at the bottom of the stroke increases, (2) the hip angle closes and (3) more hip flexion is required. Other things being equal, economy worsens. The model/table is based on a femur (thigh) segment of 40 cm, a tibia (leg and foot) segment of 50 cm, a crank length of 170 mm, and a 73-degree seat tube. Hip flexion angle assumes 20° of pelvic tilt.**

With a knee flexion of 30° at the bottom of the pedal stroke (knee angle of 150°), 170-mm cranks, and the model assumptions outlined on page 32, the hip will need to flex 100° at the top of the pedal stroke.

This may be okay if the rider is sitting up. However, as soon as the rider bends over, to a torso angle of 30°, the rider may be beyond the limits of comfortable flexion.

The rider *will* be able to lift the hips higher—either by (1) recruiting muscle fibers on the same side, or (2) by pushing the leg up by pedaling force on the other side. Extra muscular work will require more energy and worsen economy.

There is an upper limit to seat height economy. One possible explanation: Once the seat is so high that the hips rock to reach the pedals, non-propulsive muscular work is being performed and economy worsens.

If the rider wishes to keep this position (for example, for aerodynamic reasons), and wishes to improve economy, options include (1) rotating the pelvic to open the hip angle, (2) moving the pelvis forward (moving the seat forward), (3) raising the pelvis (increasing seat height), or (4) the increasing seat height equivalents: shorter cranks or cleats more aft.